



ELECTRIC STEAM BOILER

HEB SERIES

ELECTRIC STEAM BOILER
Efficiency, Reliability and Durability

Capacities from 3 to 300 BHP
Pressure max 150 PSI



- High efficiency, easy maintenance
- Easy operation, high safety level
- Compact design

SECTION VIEW

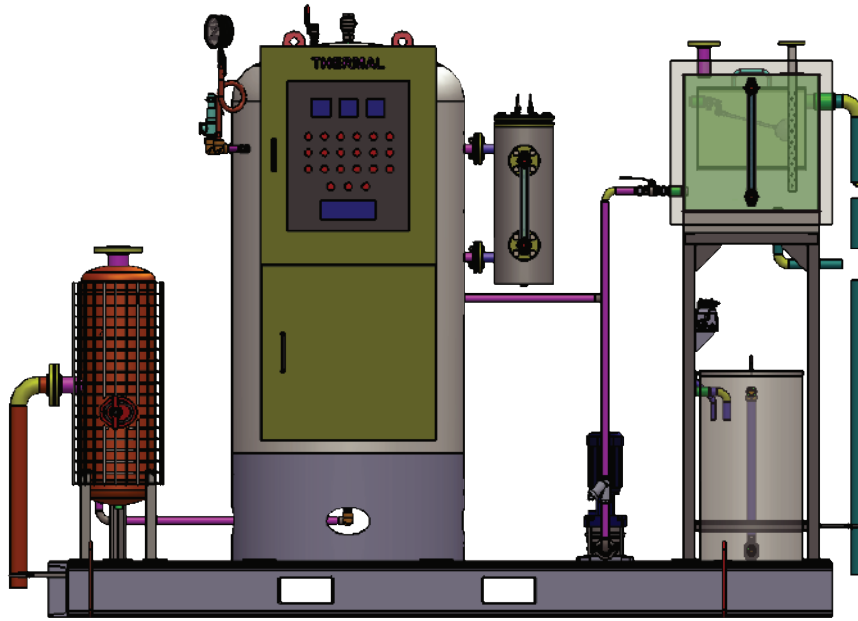

Inspected by
LLOYDS, SGS



Designed,
constructed and
stamped in
accordance with the
requirements of the
ASME Boiler Codes.

TECHNICAL DATA

MODEL	HEB50	HEB100	HEB150	HEB200	HEB250	HEB300
Steam Capacity (BHP)	3	6	10	12	15	20
Design Pressure (PSI)	150	150	150	150	150	150
Total Volume (Gal)	26	40	85	95	105	145
Electric Consumption (kW)	35	70	105	140	175	210
Chimney Diameter (Inch)	6	7	8	10	10	10
Overall Width A (Inch)	40	40	50	50	60	60
Overall Length B (Inch)	100	100	115	115	130	130
Overall Height C (Inch)	70	75	80	85	90	95

Units with steam capacities ranging from 50 to 300 BHP are designed with a horizontal cylindrical configuration.

TECHNICAL DRAWINGS

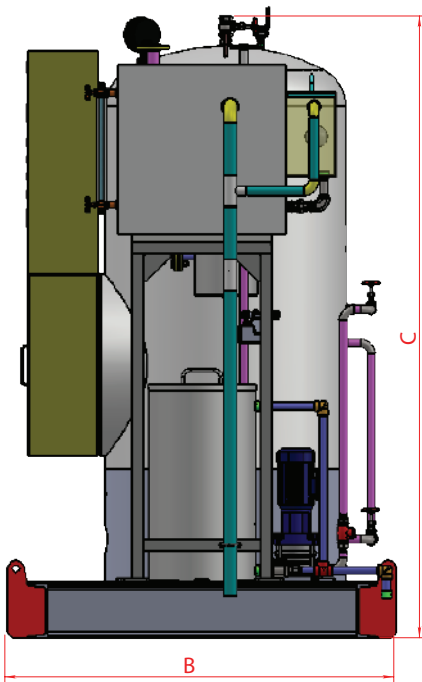

RIGHT VIEW

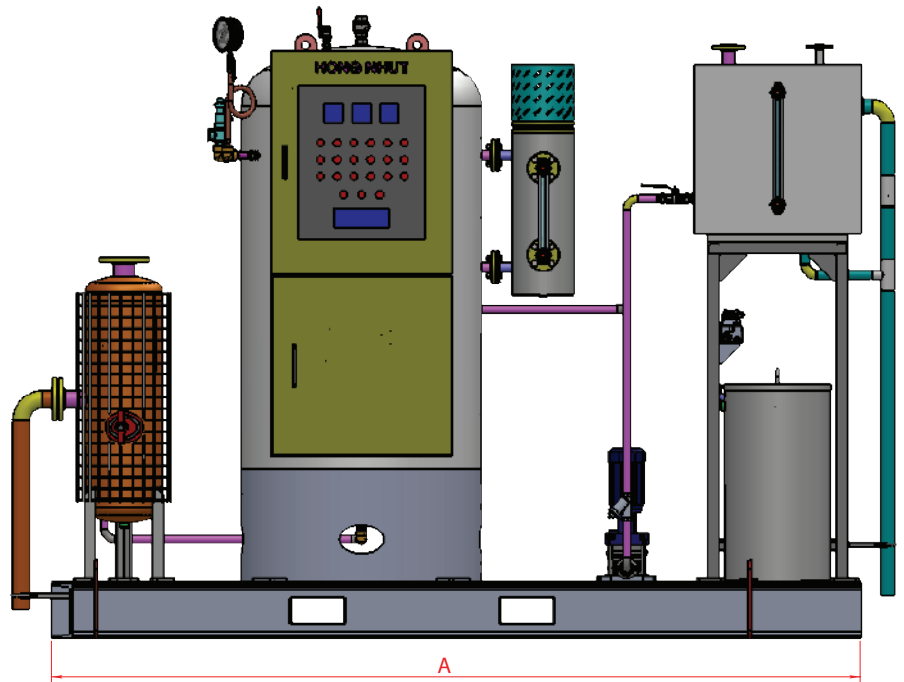

TOP VIEW

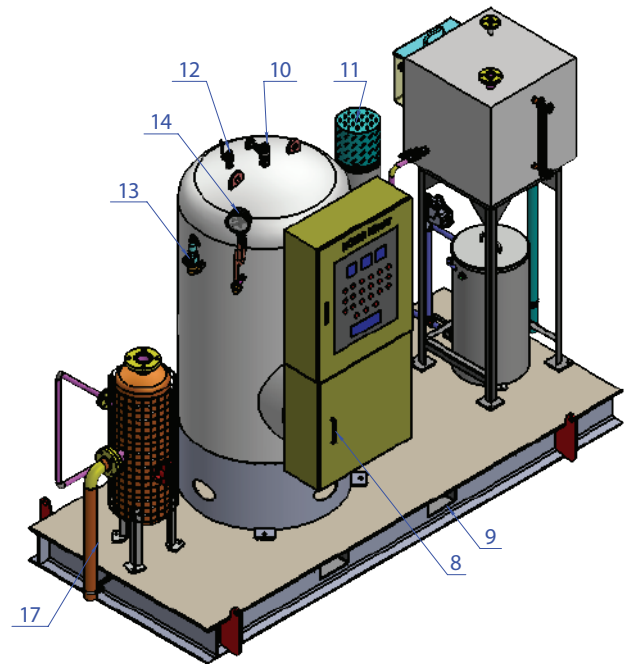
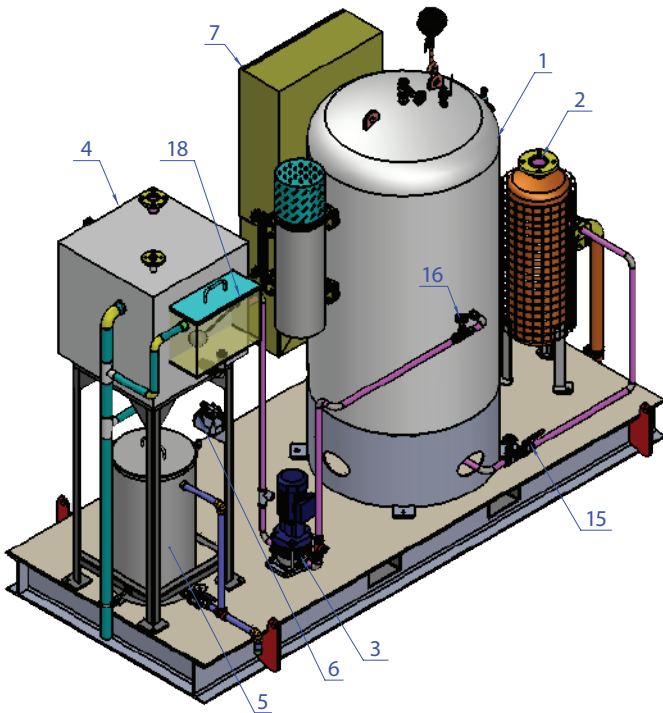

ANNOTATION:

- | | | |
|--------------------|------------------------|----------------------------|
| 1. Electric boiler | 7. Control panel | 13. Safety valve |
| 2. Blowdown tank | 8. Heater terminal box | 14. PG & PT |
| 3. Pump set | 9. Skid frame | 15. Blowdown pipe |
| 4. Feedwater tank | 10. Main steam out | 16. Suction pipe |
| 5. Chemical dosing | 11. Level pot | 17. Overflow drainage pipe |
| 6. Chemical pump | 12. Air vent | 18. Breath tank |

PRODUCT OVERVIEW

- Efficient 3 - Pass Design
- Flexibility - Capable of burning natural gas, fuel oil, digester gas, hydrogen, & various other gaseous fuels
- ASME Code Constructed & Stamped
- Competitively Priced, Easily Maintained, Designed for Efficiency
- Large Furnace Volume for Ultimate Combustion Efficiency
- Low Heat Release
- Factory Insulated - 4" Mineral Wool
- Factory Jacketed & Stainless Steel
- Easy to maintaining and operating
- Ample Waterside Clean - Out Openings
- Fully Automatic Operation
- Factory Test Fired

Electric steam boilers can be fired via conventional fuels (Diesel, LPG or Natural Gas). However, the ever increasing cost of fossil fuels, these steam boilers can be manufactured to take a large range of alternate fuels like coal, wood or even agricultural waste. All units are factory packaged with operating controls, relief valves, burner and fuel train. Installation is made simple in that only service connections are needed to place in operation. Flexible burner systems are available for firing natural gas, LP gas, #2 oil, heavy oil, or combinations. High density 4" mineral wool insulation assures lower radiant heat loss.

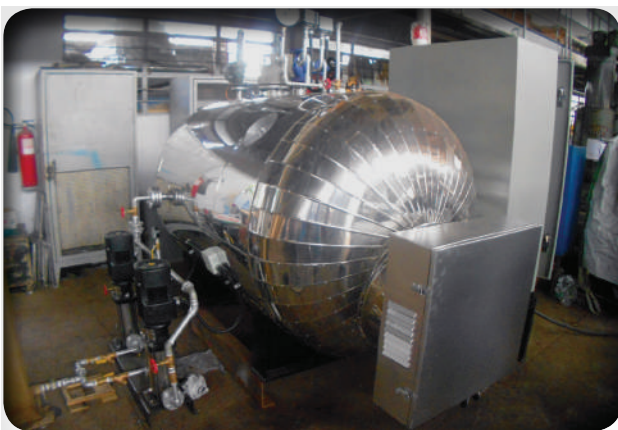

CONTACT US